

Accessibility Ramp Design and Construction Guidelines

Created June 2006
Rev 10/30/2007
Rev 11/6/2010
Rev 10/5/2012
Rev 1/31/2015
Rev 2/28/2023

Wheelchair Ramp Accessibility Program WRAP

These guidelines are provided as a service to interested parties; no liability is accepted by WRAP in relation to its safety or applicability in individual cases or in relation to its installation or adaptation for which appropriate medical, engineering or other professional services ought to be obtained. Permission is hereby given to reproduce these guidelines. WRAP is a voluntary organization which provide assistance to persons with disabilities utilizing the capabilities of retired technical volunteers, professional engineers, technicians, tradesmen and others.



<http://wrapiowa.org/>
Cedar Rapids, Iowa

Accessibility Ramp Design and Construction Guidelines

Wheelchair Ramp Accessibility Program (WRAP) volunteers build accessibility ramps for qualifying individuals and various service agencies in the Linn County, Iowa area. WRAP is primarily focused on providing home access for persons with disabilities of limited income or resources. For those with adequate financial means, a contractor should be contracted for a ramp. The accessibility need is normally identified through the WRAP Intake Coordinator at 319-369-7377 or through a service agency. Available funding depends on the individual qualifications and service agency ability to assist. The cost of a WRAP ramp construction is basically for materials, while the volunteers provide design and construction services at no cost. Each ramp design must be completed on an individual basis to accommodate the home owner, site, building permit requirements and individual needs. As a result, a generic process has been defined which is then applied on an individual basis. This process flow includes the following steps:

- Accessibility ramp need identified to WRAP
- Funding request
- Funding available
- Identify ramp designer
- Survey site
- Design ramp including ramp layout, material list, cut list, and cost
 - Cut list is very important to avoid cutting the wrong boards and ending up short!
- Obtain approval from owner and neighborhood authorities (if required)
- Obtain building permit (if required)
- Ramp build scheduled
- Materials ordered and Delivered
- Construction crew arranged
- Construction of ramp
- Notify building department of ramp completion

The project requires a considerable amount of coordination and communication. The steps which usually take the longest calendar time to complete are: Site survey, ramp design, funding arrangement, and scheduling the materials and construction crews. Completion of a ramp project will typically be 4-6 weeks long even though the actual construction is only 1-2 days.

The requirements that must be accommodated in the design of a ramp include:

Consideration	Explanation
Home entry	The choice of door to which to run a ramp is influenced by the ease of access within the home to the various doorways, the widths of the doorways, and whether any platforms, stairs or porches already exist to which a ramp could be connected.
Space limitations and obstacles	Many aspects of the design of a ramp are limited by the space available and obstacles (such as trees, buildings, and walkways) that affect where it can be run. Also, where is the lower end of the ramp to be terminated? The lower ramp termination must be on an even surface. This surface doesn't need to be level, but should have a cross-slope of 1:48 or less.
Building codes	Explicit and implicit code requirements imposed by the city or county. Some cities require a signed permission slip from the owner stating that they want WRAP to build a ramp on their property.

Standard practices	Design standards that are commonly applied in the area. Also, although they are not legal requirements for homeowners, the ADA Standards for Accessible Design http://www.ada.gov/regs2010/2010ADAStandards/2010ADAstandards.htm establish practices for commercial ramps that may be applicable or expected in home construction. Regardless of the municipality, we also follow the guidelines established by the Cedar Rapids Building Department (attached).
Specifics of the disability and means of movement	Although “standard” designs work well for many people, the specifics of how the ramp will be used MAY affect the design. Examples include: <ul style="list-style-type: none"> • If the person with a disability can only be move with his/her legs extended, wider turning platforms are needed than can be accommodated by someone who can move in a wheelchair with the feet lowered. • If the person with a disability uses a walker but is unstable on slopes, shallow steps are probably preferable to a ramp. • If the caretaker for the person with a disability is weak, the ramp will need to be less steep than normal. Conversely, a powered chair or scooter can make a steeper-than-standard ramp quite acceptable. • A design standard slope is 1:12; however several ramps have been built with 1:10 slope due to space limitations.
Landing attached to the house	The landing next to the house is normally built on frost footings to prevent frost heaving-caused interference with the door in the winter. If the front stoop is set on frost footings, then the landing would normally be set on top of the stoop with a ledger board attached to the house. If the stoop is not on frost footings, the landing can be set on posts set on frost footings. However, some city inspectors do allow the use of a ledger on the home and the other posts floating, which is usually much simpler. This can be built using a slight down-slope of the landing away from the home (less steep than 1:48), which allows floating posts in the winter from interfering with the storm door opening. This practice is sometimes allowed for mobile homes, in the same manner, which minimizes door interference issues with frost heaving and does not require frost footings. Verification of approach with the associated inspector is required.
Expected useful life of the ramp	A ramp with a longer expected useful life (more than 5 years?) or a tall structure may need to be solidly attached to the home and built on frost free footings. Ramps expected to be used for five years or less float by setting on top of the ground without footings. Some jurisdictions may require frost free footings. The justification for not using frost free footings is that they are temporary structures.
Neighborhood covenants	Restrictions, especially affecting the aesthetic qualities of a ramp, may be imposed by non-governmental agencies. For example, many mobile-home parks require that skirting be installed to hide the space underneath a ramp.
Aesthetic compatibility with the neighborhood	The appearance of the ramp, especially the type of railing treatment (balusters, rails, etc.), should be chosen to ensure that, to the extent possible without inflating the cost of a ramp, a functional ramp is not viewed as an eyesore by neighbors.
Homeowner preferences	If a ramp is needed in a home owned by someone other than the family of the person with a disability (i.e., a rental property) the requirements of the owner/landlord may trump all other considerations. Also, the home owner may desire to match some existing decking or railing design.

Client preferences	When designing a ramp that is not financed by the client or homeowner, tradeoffs must be made between functionality and cost. Some client preferences can be accommodated with little impact on cost; others cannot. The ramp designer must deal with these tradeoffs to meet the client's real needs while ensuring that an agency intending to provide home access does not end up footing the bill for a great party deck.
Access limitations	It may be appropriate, particularly when designing a long ramp, to include steps or other means for persons without a disability (such as mail carriers and delivery people) to reach the doorway without navigating the ramp.

Some standard design practices have been developed which provide simplified, low cost construction to take place. These standards are the starting point of each design, and although variations can and sometimes must be made to these standards, adherence to them is desired. The Standards of Ramp Design include:

- Construction with treated lumber
- In general "medium" length lumber should be purchased for efficiency and stability (2x4 and 2x6 boards 16' or less and 4x4 posts 10' or less). The designer may choose longer boards for a particular design in order to optimize the design.
- Purchase standard 5/4 x 6" deck board to minimize waste: 4-42" from a 14' board and 2-60" from a 10' board.
- Assemble with screws (no bolts or nails except for joist hangers)
- Standard width 42" clearance between posts (allows 39" clearance between railings)
- Use three 2x6" stringers (see 90° and 180° Landing Detail drawings for ramp framing)
- Posts 4x4" and spacing not more than 8 feet (6' nominal)
- Posts to rest on 12"X12" piece of treated 3/4" plywood for ground support
- Assure lateral stability of posts (cross bracing at least one place in each direction as needed as shown in Figures 1 and 2)
- Stringers are attached to the posts with 3 1/2" screws where possible. Also use a high shear strength screw such as Spax, Torx or lag screw, 1/4 inch by 4 inch, at sill to home and at least one at every load joint, typically 2x6's attached to 4x4s.
- Use of joist hangers required on all free stringers (not attached to 4x4) and use of hanger nails 1 5/8" required, not screws.
- Use 2x6 beams 49" long (48" minimum) or as required under stringers at every 4x4 post pair supporting the stringers unless the stringers are resting on or very close to the ground. One beam is used if the stringer continues beyond the post. A beam is used on each side of the post if stringers join at the post.
- In places where a free standing post does not have a beam cross member, 18 3/4" 2x6 blocks should be placed between the stringers close to the post to stabilize lateral movement of the post.
- Tall (5' or more above the ground) landings or ramps should have diagonal bracing between the posts to stabilize the structure.
- Use 5/4 x 6" decking boards on ramp surface and attach with 2 1/2" screws. (Shank on 2 1/2" extends through the deck board and only binds the stringer.)
- An overhead clearance of 6'8" minimum is always required above all walking surfaces.
- Highly recommend use of a hand rail with finger hold routed out of 2x6. Ready-made vertical hand rails may be purchased in only 8 ft length at lumber yards. Vertical hand rails routed from a raw 2x6 can be obtained with any desired length.
- Railing height should be 36" above decking.

- Railing extension beyond the ramp ends varies by individual constraints and installation. Where there is no physical interference and the railings are used by the client, 12" extensions can be used. However, where an extension creates difficulty for entry to the ramp, no extension might be justified. Often the railings terminate at the ramp termination.
- Enclosed sides (Guards) are required for sections of the ramp over 30" above the ground or other lower surface. The sides must be enclosed with openings less than 4".
 - If ramp is over 30" high, use three horizontal 5/4x6" deck boards or vertical balusters (must be enclosed with openings less than 4").
 - Some building inspectors object to a "ladder" type of enclosed side that consists of horizontal boards.
 - Four balusters can be ripped from a 2x6 for less cost than the ready-made balusters if acceptable to the client.
- Toe Board – use 2x4 mounted 3 1/2" above decking
- Use 5'x8' landing for 180 degree turnaround (see Figure 1, 180° Landing Detail drawing)
 - When the handrail is attached to a post that extends above the handrail, a 2x4 spacer is placed between the post and the handrail to allow room for a finger hold. It is recommended that the 2x4 extend all the way to the ground as shown in Figure 1.
- Use 5'x5' landing for 90 degree turn (see Figure 2, 90° Landing Detail drawing)
- A 5' long level ramp section (resting landing) or a landing is required after each continuous 30' of ramp length or 30" of ramp rise.
- Hold downs are sometimes required by local codes for wind loading. If required, one approach is to use 12-15" earthen hold downs (not dog-screw types) and cable from the eyelet to each section of the ramp. If the ramp is constructed over concrete, Tapcon screws holding metal plates can be used.
- An End Post Bracket is used to support the two end posts. This is fabricated from steel angle iron and plates as shown in the drawing in Figures 3 and 4, Ramp Termination drawings
- A Ramp End Assembly is constructed from wood as shown in the drawings. This may either be fabricated in advance or on site. The structure is screwed together from the bottom and attached to the end posts with screws through the 2x4 toe board. A 3/4" plywood base may be required under the End Post Bracket and Ramp End Assembly to stabilize it on the ground. (see Figures 3 and 4, Ramp Termination drawings and Appendix A.) It is very desirable to terminate the ramp at an even surface so the tapered edge of the last deck board is tight against the ground. When terminating on uneven concrete, consider fastening the end board down with a Tapcon screw into the concrete.
- Building codes are followed (see Figure 5, Cedar Rapids building code handout)
- A great deal of time may be saved at the construction site by developing an accurate bill of materials in advance.
- It is also very helpful to create a "cut list" which includes each board and its length, and where the board will be used in the construction.

Figures:

- | | |
|---------------------------------------|--------------------------------------|
| 1A. 180° 5'x8' Landing Detail | A1-5. Stringer Cuts |
| 1B. 180° 5'x9' Landing Detail | A6-12. Terminal decking construction |
| 2. 90° Landing Detail | B1. Handrail Profile |
| 3. Ramp Bottom Termination Assembly | C1-3. Stair Design |
| 4. Ramp Bottom Termination Detail | D1-6. Skirting |
| 5. Cedar Rapids Building Code Handout | E1-5. Jigs |
| 6-10. Photos of typical ramps | F1-5. Cutting tapered end boards |

Appendices:

- A. Ramp Termination Construction Guidelines
- B. Vertical Handrail Construction Guidelines
- C. Stair Design Guidelines
- D. Skirting Installation Guidelines
- E. Jigs used in construction
- F. Cutting tapered end boards
- G. Walker step construction
- H. Baluster Guidelines

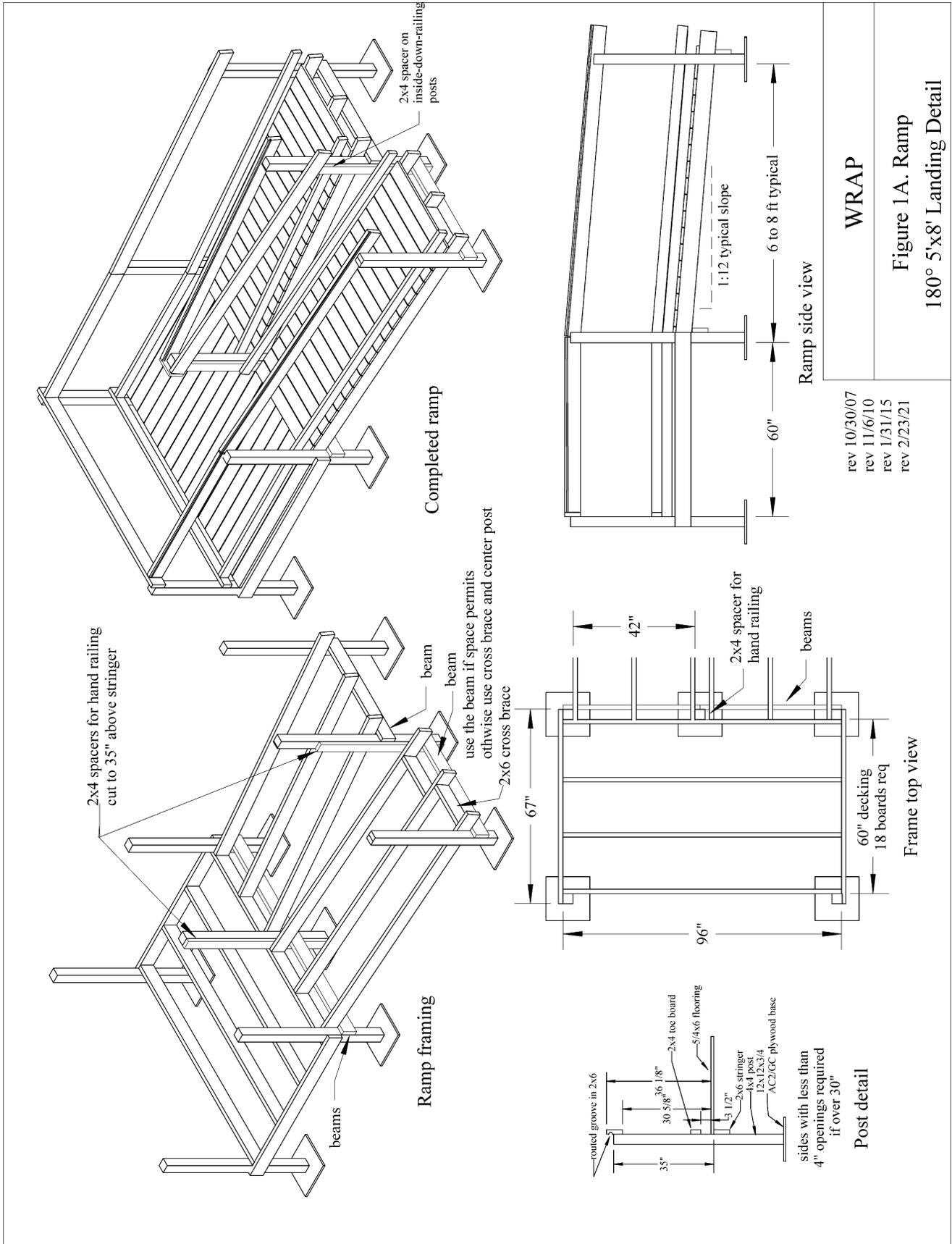

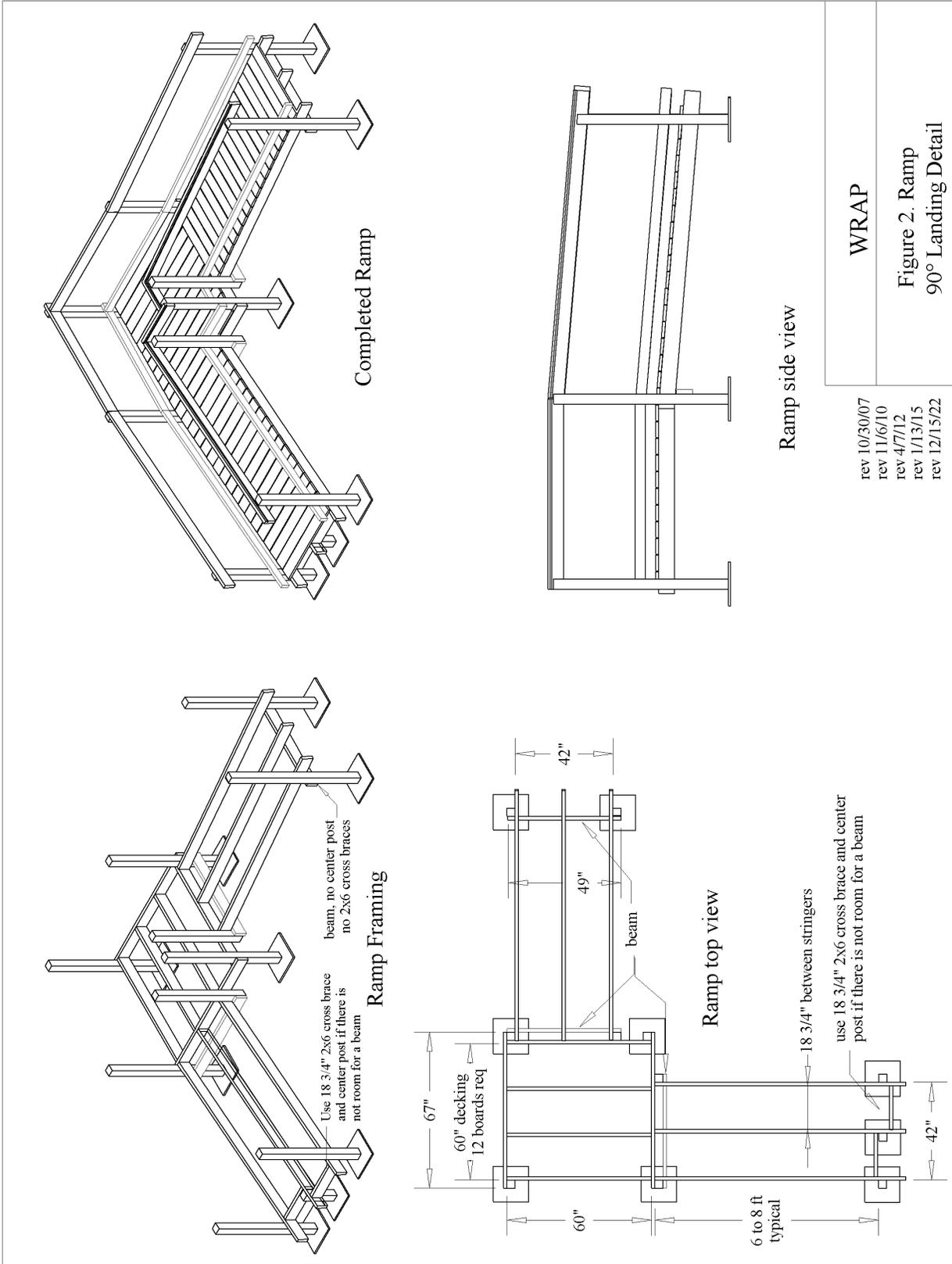

WRAP

Figure 2. Ramp
90° Landing Detail

- rev 10/30/07
- rev 11/6/10
- rev 4/7/12
- rev 1/13/15
- rev 12/15/22

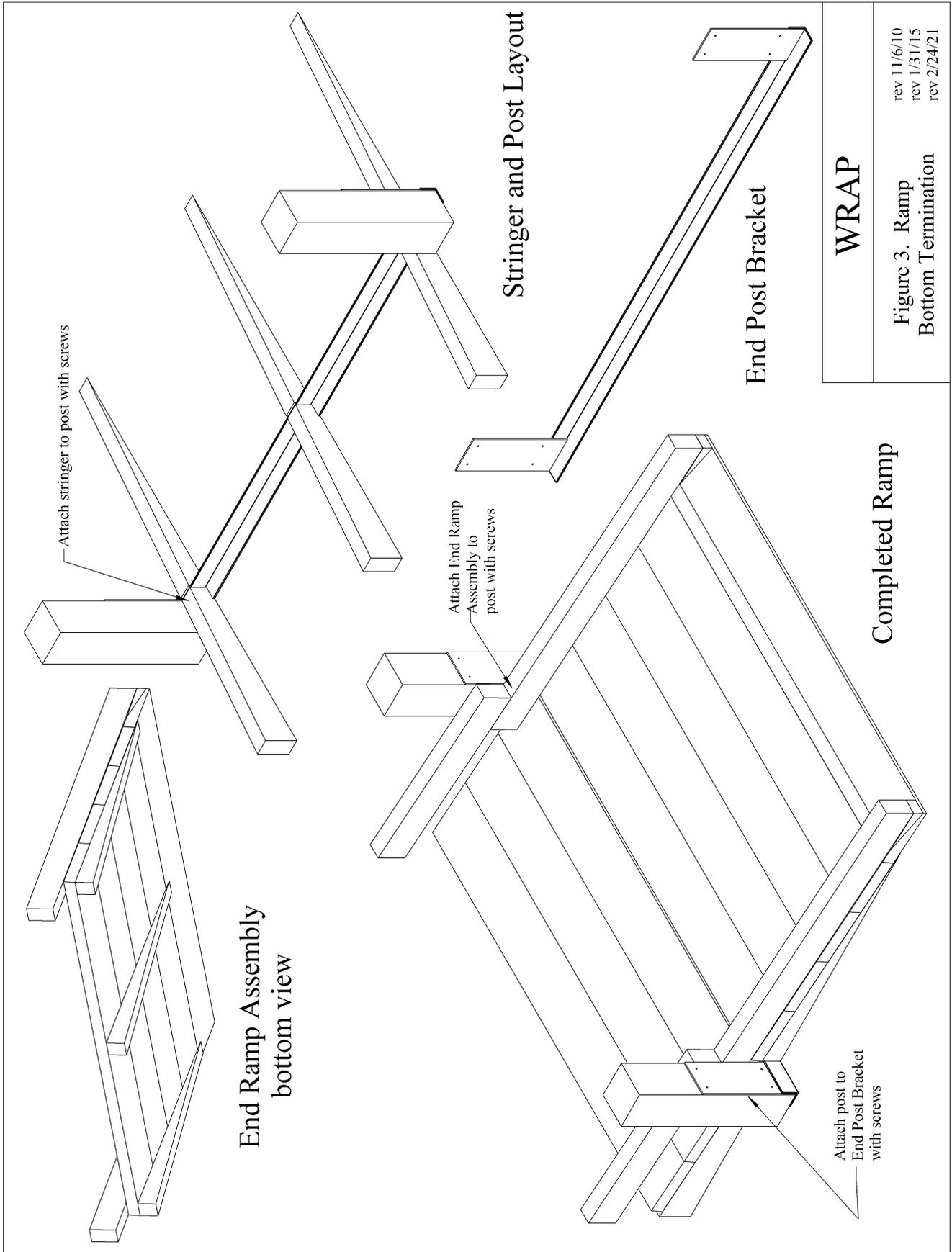

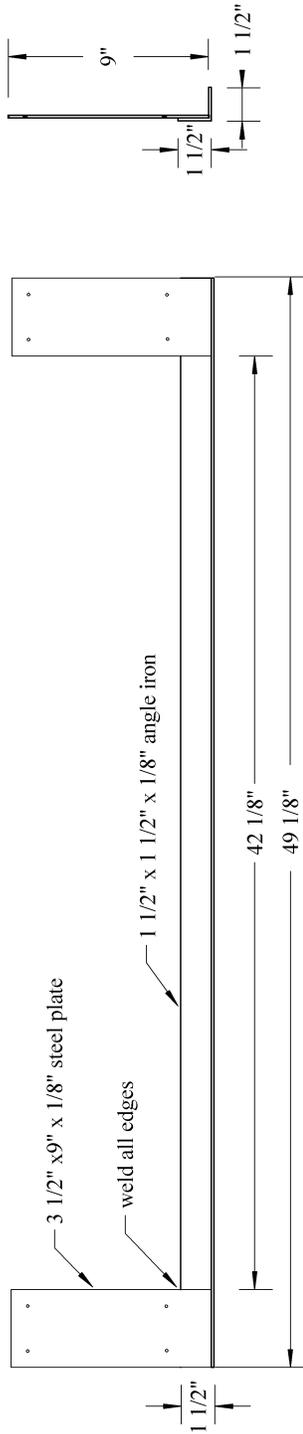

End Post Bracket

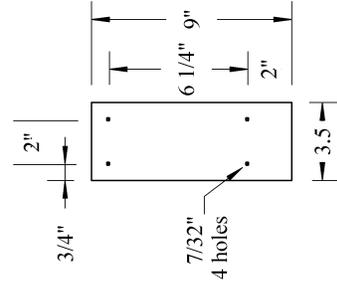

3 1/2" x 9" x 1/8" steel plate (2)

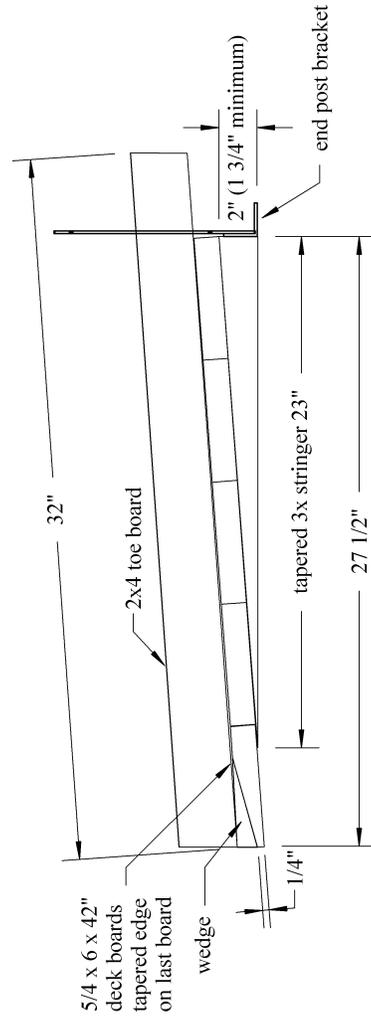

End Ramp Assembly

rev 11/6/10
rev 1/31/15
rev 2/24/21

WRAP

Figure 4. Ramp
Bottom Termination

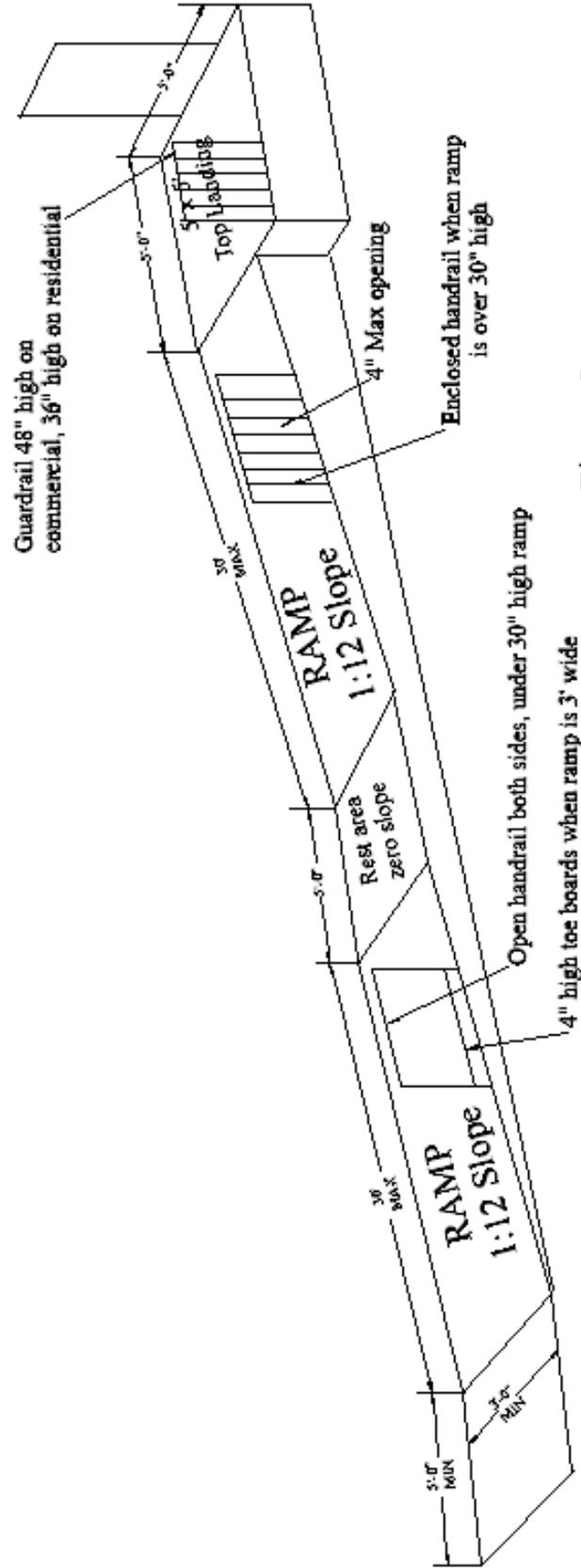

Figure 5
Cedar Rapids building code handout

Photos of typical ramps

Figures 6 through 10 are photos of a typical ramp constructed using the design standards described above. The ramp is 33 feet long with a 180° landing.



Figure 6. Ramp frame with 180° landing. Notice cross bracing



Figure 7. Stringers into Ramp end post assembly.



Figure 8. Ramp frame. Notice cross braces.



Figure 9. Completed ramp.

Appendix A. Ramp Termination Construction Guidelines

Termination of a ramp has special issues because it is so close to the ground. Often digging is not possible and when it is, it is difficult and time consuming. WRAP has developed several techniques to construct solid ramp terminations that are described here. The ramp usually consists of a Termination Assembly and the End Stringers that extend from the fully above ground ramp structure to the Termination Assembly. Both the End Stringers and Termination Assembly construction considerations are discussed here.

End Stringer Construction

When terminating the ramp on concrete or on a hard reasonably level surface that requires little or no digging, the stringers approaching the ramp termination must be tapered to rest on the ground. In other cases it may be desired to have the ramp butt into the edge of a concrete or other hard surface so there is a smooth level transition to the ramp without using a tapered deck board. Occasionally the ground is sloping away from the ramp at the planned ramp termination and will require a very thin taper on the stringer which may be very weak. In this case the stringer should be dug in with little or no taper.

Figure A1 shows a common situation where the termination assembly is set on concrete or reasonably level ground and the stringer must be tapered to lay on the ground. The 2x6 stringer is set exactly 5 1/2" above its final resting place and a line is drawn on the stringer that is 5 1/2" above the ground. When marking the cut line, the stringer should be positioned so that the bottom of the stringer is exactly at the level planned for the top of the stringer when it is installed. One end of the stringer is set on the previously installed up-ramp stringer and the other end of the stringer is shimmed so that a projection of the bottom surface of the stringer intersects the ground 2"-3" from the planned end of ramp. Figure A2 shows the final installation using a tapered end deck board.

If the ramp will end by butting up to a concrete, dirt, or other solid surface, the ramp can end with a whole deck board rather than the tapered end board. The ground approaching the solid surface edge must be an inch below that surface so the last deck board can be flush. Marking the cut line is similar except the stringer is set on top of a deck board at one end and shimmed so the bottom surface of the stringer projects to the top edge of the solid surface as shown in Figure A3. The cut line must be marked 6 5/8" above ground level to account for the deck board thickness.

If the ground has a downward slope at the ramp end as shown in Figure A4, the required taper on the stringer leaves insufficient thickness to support the ramp. The stringers could be partially dug in to lower the ground level under the stringers and use the tapering method of Figure A1. A better solution is often to use a full width 2x6 extended all the way to end of the ramp as shown in Figure A5 where a trench is dug for the stringers. The end bracket is still used to provide lateral support for the end posts.

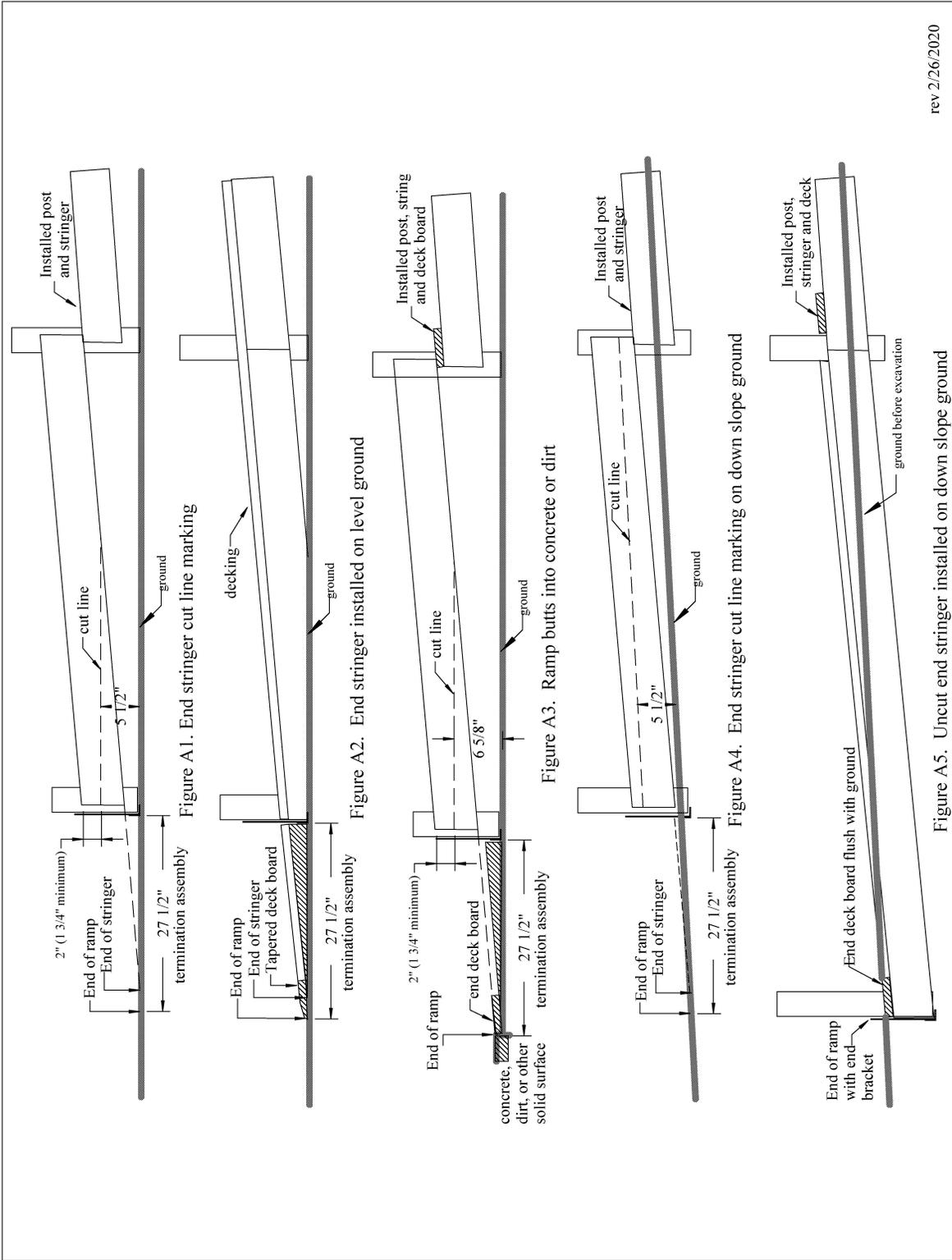

rev 2/26/2020

Termination Assembly Construction

This is a general approach to construction and installation of the termination assembly (TA). This assembly fits between the steel end bracket (last 4x4 posts) and the end of the ramp. The use of the end bracket and this assembly allows the ramp to terminate on hard surfaces like concrete without digging holes or using Tapcon screws.

1. Decide length of termination desired. Standard design uses 5 deck boards and is about 28" long. Standard 42" deck boards are used and the last board is typically tapered to minimize the abrupt start up the ramp.
 - a. Options including using less than 5 boards, especially if ending on a slight "upslope."
 - b. The TA determines where the steel end bracket, last two 4x4 posts and ends of final stringer will be.
 - c. If the surface just before the termination is soft and can be excavated, a full thickness deck board should be considered rather than a tapered board.
2. Install the steel end bracket and final 4x4 posts. This step finalizes the final stringer lengths, and verifies the length of TA required. NOTE: If the position of the end bracket has been confirmed, its installation can wait until the TA is completed.
3. Locate a flat area for assembly and gather the needed boards: 4-standard 42" deck boards, 1-tapered 42" wide deck board, and 2-2x4x32" toe boards with 5 degree ends.
4. Construct the Termination Assembly **UPSIDE DOWN**.

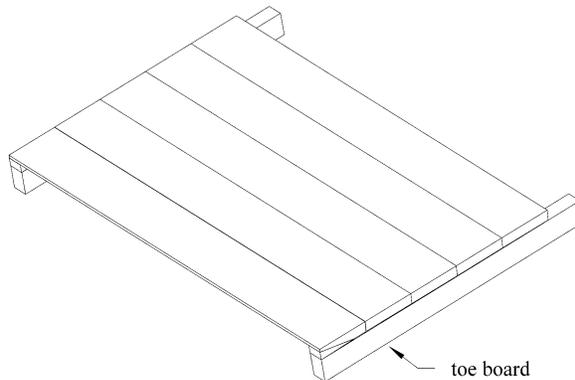

Figure A6. Termination Assembly upside down

- a. Place 2 toe boards 42" apart with 5 degree ends proper and mark 3 3/4" from one end on each.
- b. Place a deck board on the toe boards at the 3 3/4" line just marked. NOTE: I usually place all 4 regular deck boards on the two toe boards just to stabilize things.
- c. Use a framing square to line up the deck board at 90 degrees to one toe board and attach with two 2 1/2" screws.
- d. Measure the distance between the outsides of the two toe boards and make this measurement 42". This is **IMPORTANT** to make sure that this assembly will fit between the two 4x4 end posts and end bracket "wings."
- e. Use framing square to line up the second toe board at 90 degrees to this first deck board with the deck board at the 3 3/4" line. Attach with 2 screws.
- f. **IMPORTANT**...measure to make sure the toe boards are parallel and 42" apart (outside to outside) at both ends, **AND** recheck that first deck board is still perpendicular to both toe boards.

- g. Attach remaining 3 standard deck boards one at a time by snugging them up to the prior one (don't use spacers) and using 2 screws at each end of each.
 - h. Attach the tapered deck board using two screws on each end. Place the sawn, tapered side down (it will be showing when the assembly is placed right-side up). It is **IMPORTANT** to use the wedges where the tapered board is not full thickness. NOTE: It is sometimes helpful to predrill the tapered board to prevent splitting from the screws.
5. Install end bracket and 4x4 posts are if not yet installed (#2 above). It is **IMPORTANT** to install the 4x4 posts vertically, but equally **IMPORTANT**, they cannot extend into the 42" wide space between the two bracket "wings". Note: the end bracket must horizontally aligned with the ground at the termination, which may not be level. Therefore the vertical posts may not be 90° from the bracket.
 - a. 4x4 posts should be long enough to be 35" above the tops of the stringers. Attach end bracket to posts with 2 ½" screws.
 - b. See other information on cutting the stringers to fit. Their ends should be 1 ¾" height minimum.
 - c. Attach outside stringers to 4x4 posts using 3 ½" screws. The center stringer should be resting on the steel angle iron.
 - d. Install a standard 42" deck board across the ends of the stringers with its edge even with the angle iron.
 6. Place TA in position to verify that it fits into space properly and its tapered board end will fit "flush" to surface at ramp's end. This also verifies that the assembly will fit between the two 4x4 posts.
 7. Construct "wedges" to be used as extension of stringer to support deck boards.
 - a. Construct each wedge as if all three are different (they most often are not the same size).
 - b. Measure the height for one "outer" wedge at the angle iron bracket. Then measure the expected height 23" toward the end from the bracket (this is often 0" (zero) for concrete surfaces).
 - c. Construct a wedge (triangular) with the dimensions from b. above and place it in place to see how it fits. Adjust as necessary.
 - d. Install first wedge with one screw to simply hold it in place for now.
 - e. Repeat this process for the other outer wedge, test it, and when the fit is right, install with one screw.
 - f. Measure the height of the center wedge like b. above, construct the wedge and test it. It is **IMPORTANT** that this wedge supports the center of the deck boards...adjust if necessary.
 - g. When all 3 wedges fit properly, attach the outer wedges with more screws. The center wedge can be screw both from the top or bottom, being careful not to go too deep if screwing from underneath.
 8. Install completed TA at the end of the ramp. It is **IMPORTANT** that this assembly does not "lift" the tapered board end on one side or the other. The tapered board edge **MUST** lay against the hard/concrete surface. This can be tested by standing on the upper part of the TA and making sure the end stays down.
 - a. Sometimes adjusting is necessary to keep the TA end in contact with the concrete.
 - b. Rarely, balusters made of 2x4s can be placed between the railing and the toe boards at the end of the TA toe boards "pushing" them down to hold the TA edge tight against the concrete.

9. Attach TA toe boards with two 3 1/2" screws. **IMPORTANT**-This should be done while standing on the tapered board to assist holding it down during attachment.
 - a. The regular ramp toe boards rest on top of the TA toe boards and therefore must be attached after the TA.



Figure A7. Screw deck boards to toe boards while upside down.



Figure A8. Cut 3 wedges for TA stringers.



Figure A9. Completed TA - upside down.



Figure A10. Completed TA - right side up.



Figure A11. End post bracket



Figure 12. TA inserted into end post bracket

Appendix B. Vertical Handrail Construction Guidelines

Tools required:

- Two routers with 1/2" collets.
- Freud 99-444 or equivalent 1-3/16" (Dia.) Handrail Bit.
- Freud 34-124 3/8" or equivalent Radius Rounding Over Bit.
- Hand held electric planer (Optional).
- Random orbit sander.
- 80 grit sanding disks.
- Equipment to support the 2x6 such as a Workmate®

Construction process (see figure B1):

1. Select the best 2x6 material before the saw guy starts cutting them up. Selection should be made based in lack of defects such as knots and slits along one edge.
2. Inspect the material for any foreign objects that may damage the cutting tools.
3. Plane the top edge using a hand-held electric plane (Optional).
4. Plane the sides if needed (Optional).
5. Route the finger hold along ONE side with the bit adjusted to place the center of the radius 1" below the top. It is best to do this in two passes.
6. Route the round over along both of the top edges. Note: if the bearing on the bit falls into the finger hold it will be necessary to run the bearing on the top of the 2x6 or route the round over before the finger hold. Another option is to route the round over first.
7. Sand the top and sides to provide a smooth splinter free surface.

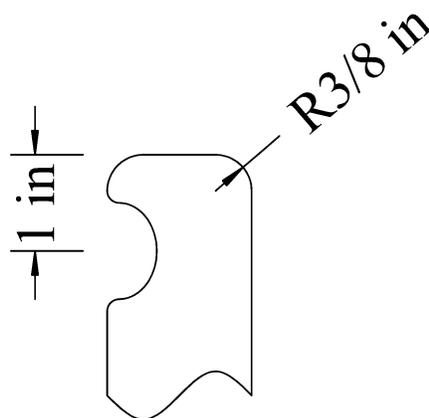

Figure B1. Handrail profile

Appendix C. Stair Design Guidelines

If the client desires and space is available steps can be added off the upper landing.

The steps are constructed using three 2 by 12 stringers with two 42 inch wide deck boards as treads and a deck boards as toe kicks. If the rise is greater than 6 ½ inches a filler should be added below the full width toe kick.

A 49 inch 2 by 10 beam is added under the landing stringer to support the center step stringer. Attach the center stringer to the beam using a stub 4 by 4 post.

A 49 inch 2 by is ripped to match the height of the bottom riser and serves as the bottom toe kick and support for the handrail posts.

2 by 6 handrails are installed 36 inches above the nose of the tread. 2 by 4 toe boards are installed sitting on the tread nose.

Riser calculation - see figure C1.

1. Measure the approximate total rise.
2. Divide this number by 7 and round this number up to the nearest integer. This will be the number of risers.
3. The run will be the number of risers minus one times 11 inches.
4. Measure the actual total rise at the run distance from the landing.
5. Determine the rise value by dividing the actual total rise by the number of risers.
6. Note any variation from level where the stringer will land on the ground. When cutting the stringer allow extra material to permit scribing the bottom of the stringer. The goal is to have the end of the stringer equal to the riser height minus 1 3/6 inch.

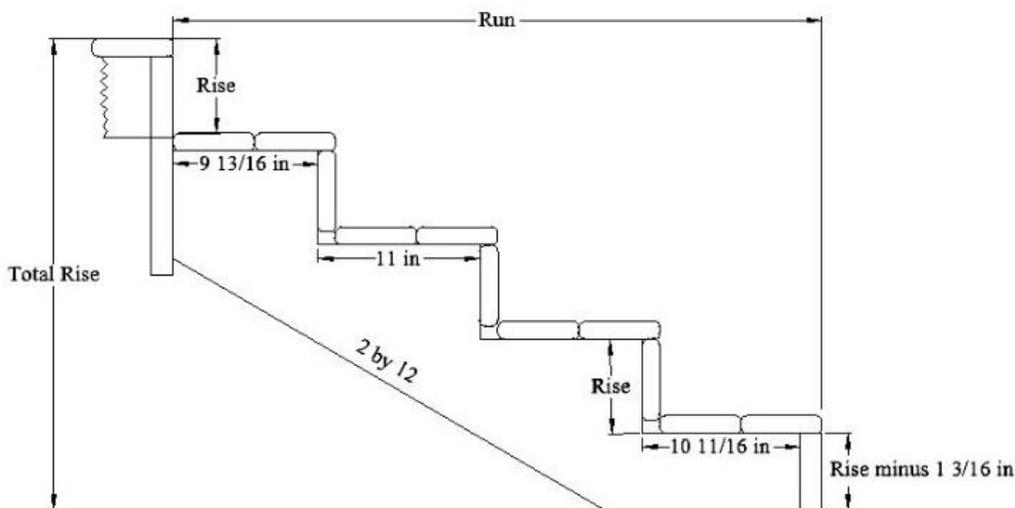

Figure C1 Stair stringer

Note: There is an app available for Apple and Android phones that will do these calculations. Search the app store for WRAP-iowa.

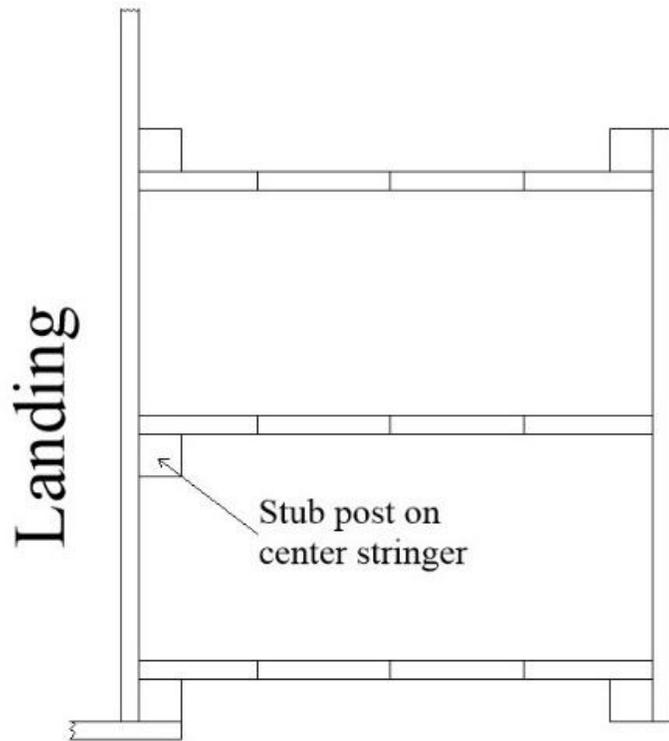
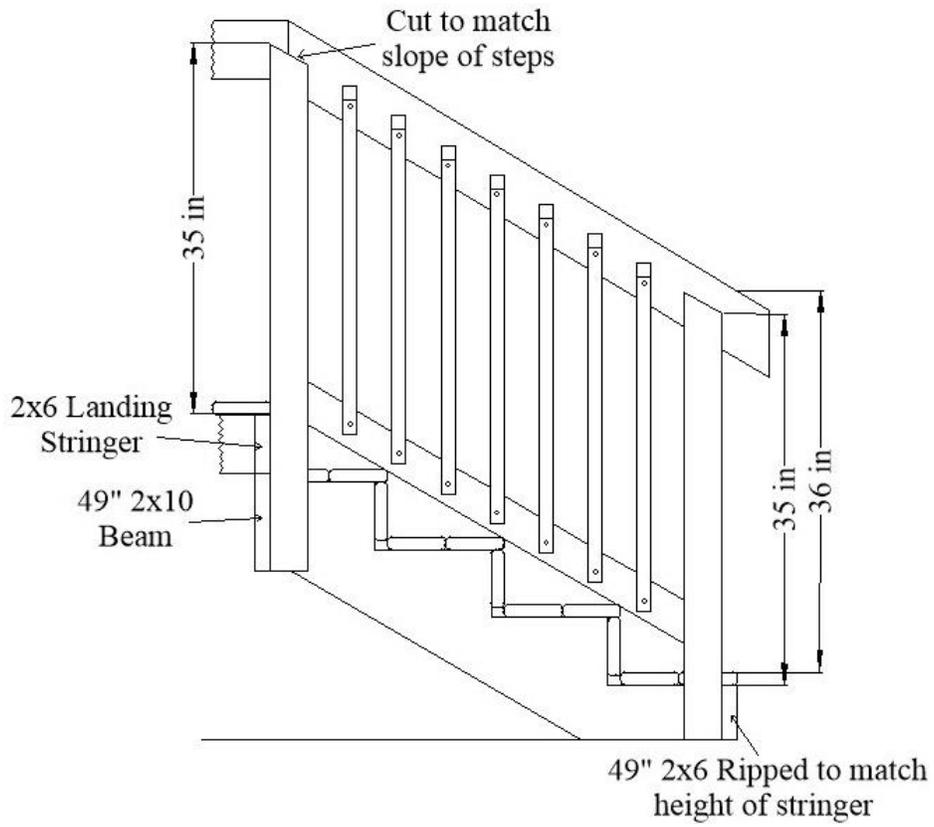

Figure C3 Stair top view

Appendix D. Skirting Installation Guidelines

D1. Introduction

Skirting is added to ramps, typically only in mobile homes which have a requirement specified by the mobile home court owners. Skirting prevents various animals from camping underneath ramps and provides a consistent look to the home and ramp. Aesthetically, the ramp and home would have a finished and consistent look throughout the property.

To give the skirting a smooth and consistent look from the home throughout the entire ramp, filling in gaps as described in the Installation Guide is necessary. Filling in gaps between 4x4's and from platforms to decks enables a smooth look to the skirting and enables installation to complete with much more ease.

Vinyl skirting pieces are easily cut with a circular saw, and portable saws are especially handy. A vinyl saw blade can be used, or simply reverse the standard wood cutting blade in the saw for even, not too aggressive cuts. Old (reused) skirting pieces become much more brittle and sometimes cannot be cut without chipping and breaking off pieces and must be discarded.

Sheet metal screws are normally used for attachment of vinyl pieces to the ramp, and hex heads are convenient. Using nails for attachment can be difficult to use, sometimes splits the vinyl, and makes disassembly more difficult.

D2. Installation Guide

Skirting consists of four components: skirting panel, inside top, outside top and a BTM track (bottom track). The following discusses installation and issues related to each.

D2.1 Inside/Outside Top

Inside/outside top comes in 12 foot pieces. Estimating the length required for a ramp is straight forward, starting at the beginning of the ramp and ending at a point where the 2x6 joist of the ramp is flush with the ground or pavement.

There are two additional unique pieces of construction required.

First: A 2x4 filler is added to the top of the ramp as shown in the pictures below (Figures D1 and D2). This 2x4 filler is flush with the top of floor joist and provides a base to attach the Inside Top to. The 2x4 filler needs to be installed on one side of the decks, since two sides will have sides flush with 4x4 posts seen on the right side of Figure D1.

Second: A triangular piece of wood from a platform to the ramp as shown in the pictures below (Figure D1 and D2).

This triangular spacer block provides a smooth transition from a deck to the ramp. Both the 2x4 filler and the triangular spacer blocks are attached flush with the top of the 2x6 joists.



Figure D1. 2x4 filler, triangular spacer block and track support

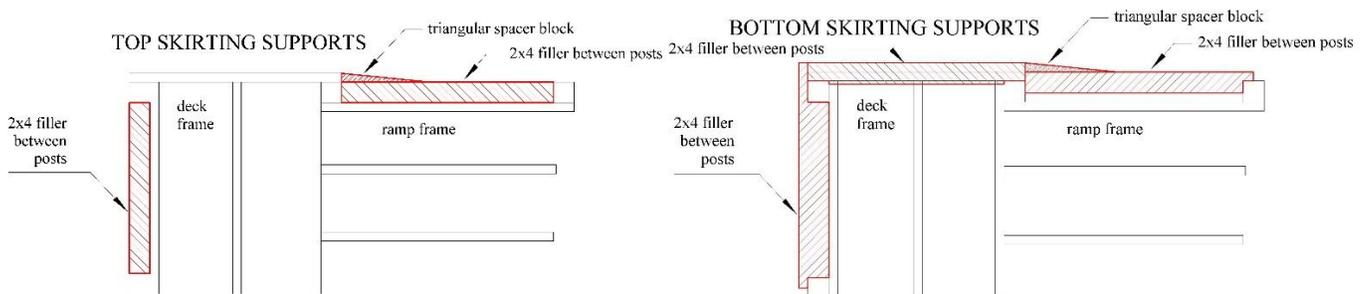

Figure D2. 2x4 filler and triangular spacer block provides a smooth surface for the skirting

D2.2 BTM Track

BTM Track comes in 12 foot pieces. This is the track in which the panels go into at the bottom of the skirting. There are two different installations of BTM track: On the ground or on pavement. The two installations are represented by the two pictures below.

The first (Figure D3) showing a 2x2 board attached to the inside of the track when putting the track on pavement. This provides stability for the track. The second (Figure D4) showing a BTM Track placed on top of a 2x4 when placed on the ground. This enables grounds keepers or owners to trim grass without destroying the track.



Figure D3. BTM Track with 2x2 base on pavement



Figure D4 BTM Track with 2x4 base on dirt

The BTM track must always be placed directly underneath the Inside/Outside Top so that the skirting will always be vertical. This includes compensating for the triangular spacer block described above in Inside/Outside Track. When installing either the 2x2's or 2x4's, ends should be toe screwed to 4x4's for stability. 2x4's can also be attached to the ground with long spikes, some of which may be in the warehouse.

D2.3 Skirting Panel

Skirting comes in 12 foot panels and are 13 inches wide. When estimating the required square footage needed, reduce the height of a panel needed by 6 inches (6 inches encompasses the distance for the inside/outside (top) and the BTM (bottom)). Paneling will end approximately 4 inches prior to where the ramp joist touches the ground or pavement. The skirting does not necessarily have to be cut with the 5 degree ramp slope angle at the top. Cutting it horizontally reduces waste and the "outside top" piece covers up the gap created.

D2.4 Remaining Gaps

Once skirting installation has been completed, there will be remaining gaps between parallel upper and lower ramp sections connected to a 180° landing. In most ramp installations, these gaps must be closed. This is usually done by filling in the vertical gap with decking boards, then extending ramp flooring deck boards across the horizontal gap created by the 4x4 posts. During construction, the installation of vertical deck boards should be completed prior to the installation of the ramp deck boards. An example of this is shown in Figure D5.



Figure D5. Vertical deck board fills a narrow gap at the end of the ramp instead of a skirting panel



Figure D6. Completed skirting.

Appendix E. Jigs used in construction

WRAP has developed several jigs that hold and align the lumber to simplify and speed up ramp construction. Ramp projects are frequently completed in a half day with the benefit of the jigs and a large experienced crew.



Figure E1. Landing framing jig.

The jig holds 2x6 joists for the landing frame so that they will line up with a 4x4 post. Screws into the end grain and 2x6 hangers are installed with the help of the jig.



Figure E2. Frame and stringer support jigs. These are 2 types of jigs that hold the 2x6 frame or stringer while the ramp is being aligned and the posts are installed.



Figure E3. Deck board spacer. The spacer controls the deck board spacing while it is being screwed down. Two spacers are shown upside down.

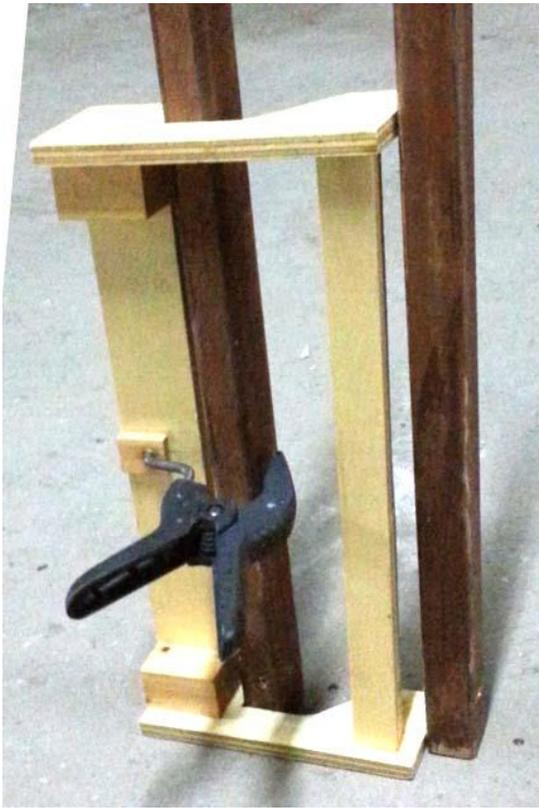

Figure E4. Baluster alignment tool Holds a baluster 4" from and parallel to the adjacent baluster.

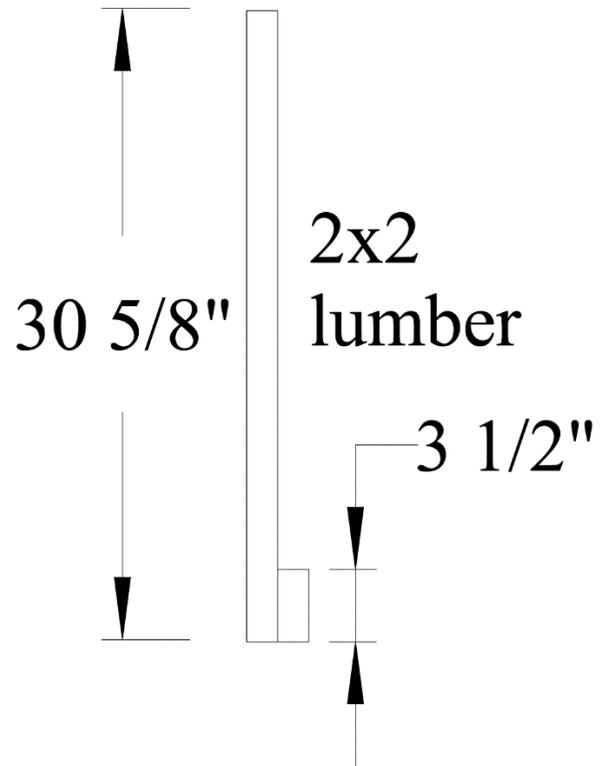
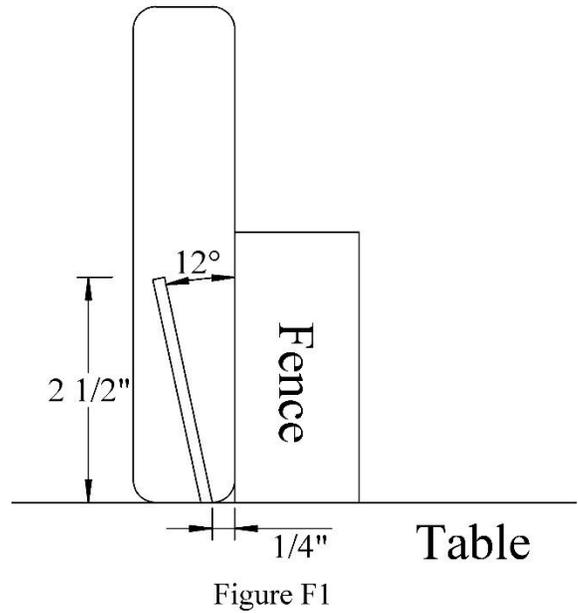

Figure E5 Handrail toe board spacer tool.

Appendix F. Cutting tapered end boards

The tapered end boards can be cut using a 10 inch table saw. Set the blade to full height and 12 degrees. Set the fence no less than 1/4 inch from the blade at the table height. Make the first cut.



Move the fence to the other side of the blade and adjust the position such that the two cuts will meet. Make the second cut.

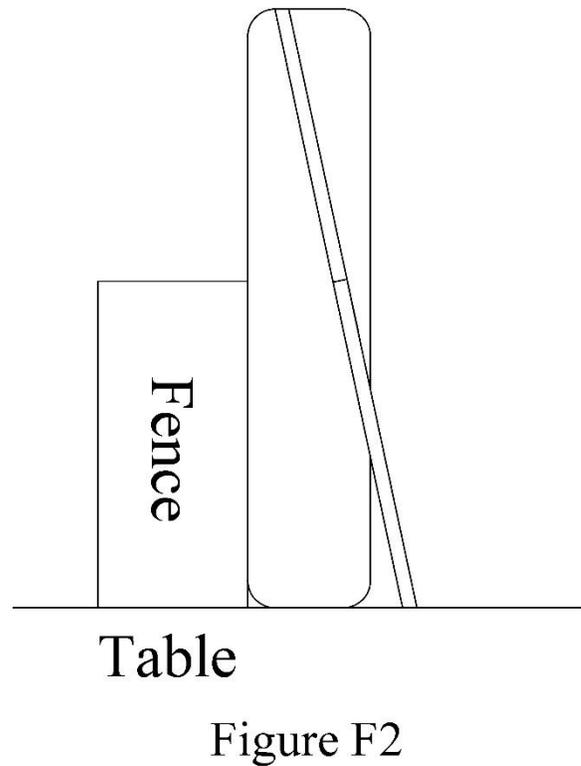

Using 2 by stock cut wedges at 12 degrees and 4 inches long. Attach the wedge to the ends of the taper board using staples. Drill two 1/8 inch holes in each end. This is to prevent splitting that material when attached with screws

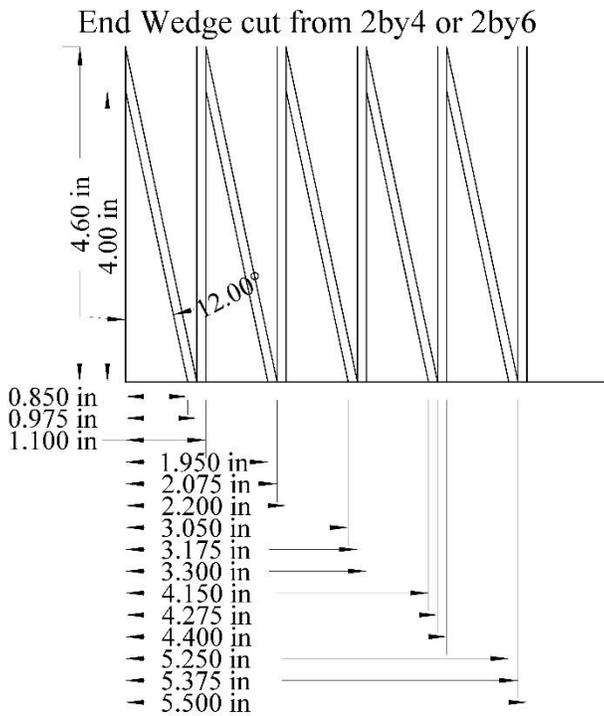

Figure F3

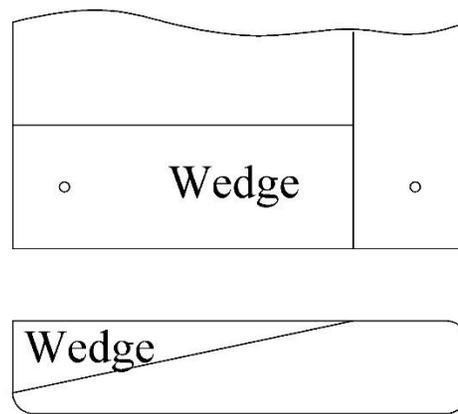

Figure F4

Ramp End Assembly

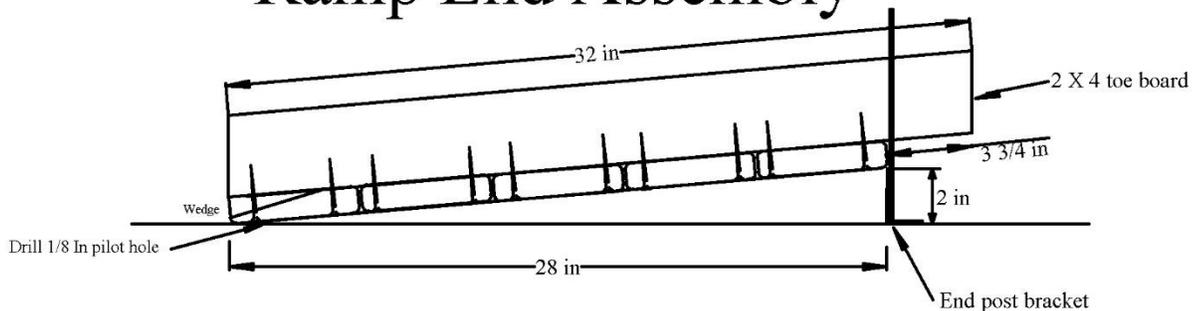

Figure F5

Appendix G. Walker Steps

If the client uses a walker it may be appropriate to use walker steps in place of a wheelchair ramp. Walker steps are stairs where there are deep treads and short risers. Since walker steps are shorter in overall length than ramps, they are a good alternative if space is an issue.

Walker step construction is very similar to landing construction on wheelchair ramps.

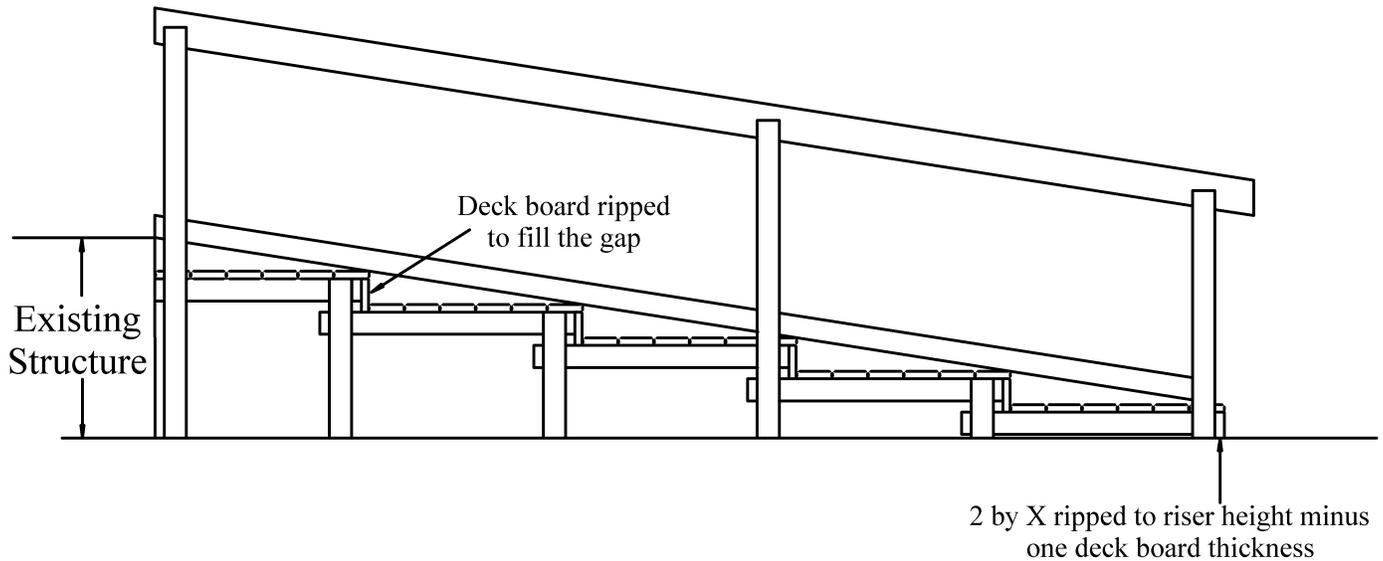

Figure G1

Each step consists of a 2 by 4 frame supported in all four corners by 4 by 4 posts. The dimensions given in figure G2 are for steps that are six deck boards deep.

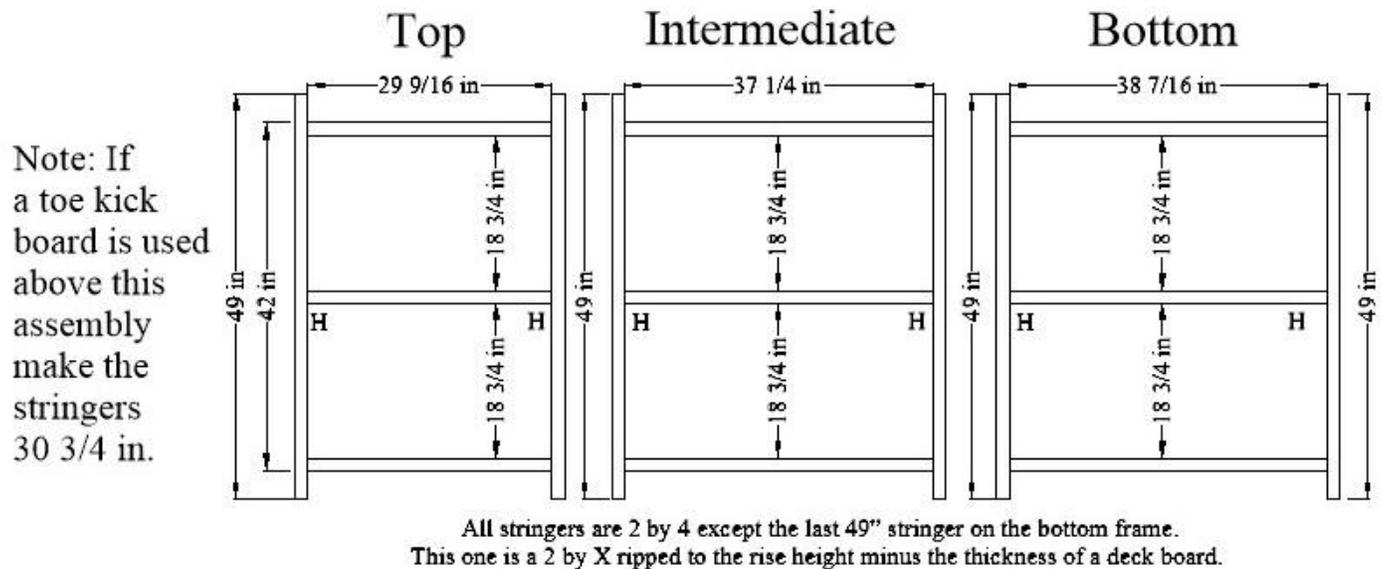

Figure G2

If desired the steps can be made larger or smaller by adding or subtracting 5 5/8 inches for each deck board added or subtracted. A hanger should be used at each location marked with an H.

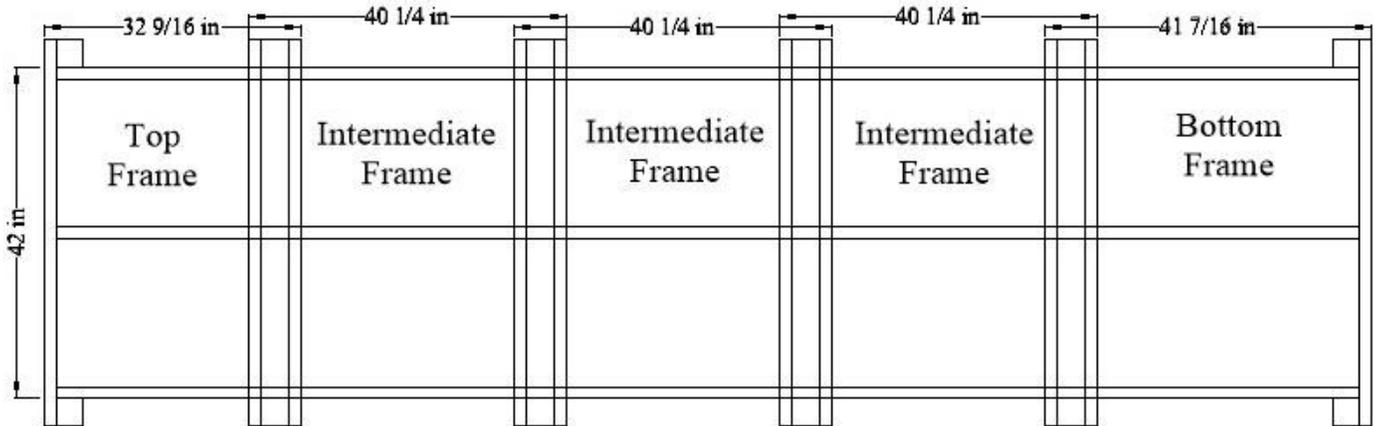

Figure G3

The last 49 inch stringer on the bottom step should be 2 by X material ripped to the riser height minus the thickness of one deck board. This provides lateral support for the posts.

Long posts are placed at the top and bottom ends to support the handrails and toe boards. Long intermediate posts should be placed such that there is no more than eight feet between posts.

Handrails and toe boards are installed similar to ramps. The toe boards should rest on the nose of the steps. If the height of the step is more than 30 inches above the ground, guard rails or balusters must be used.

In some cases it may be desirable to make a 90° turn in the steps. The following figures show how this could be done.

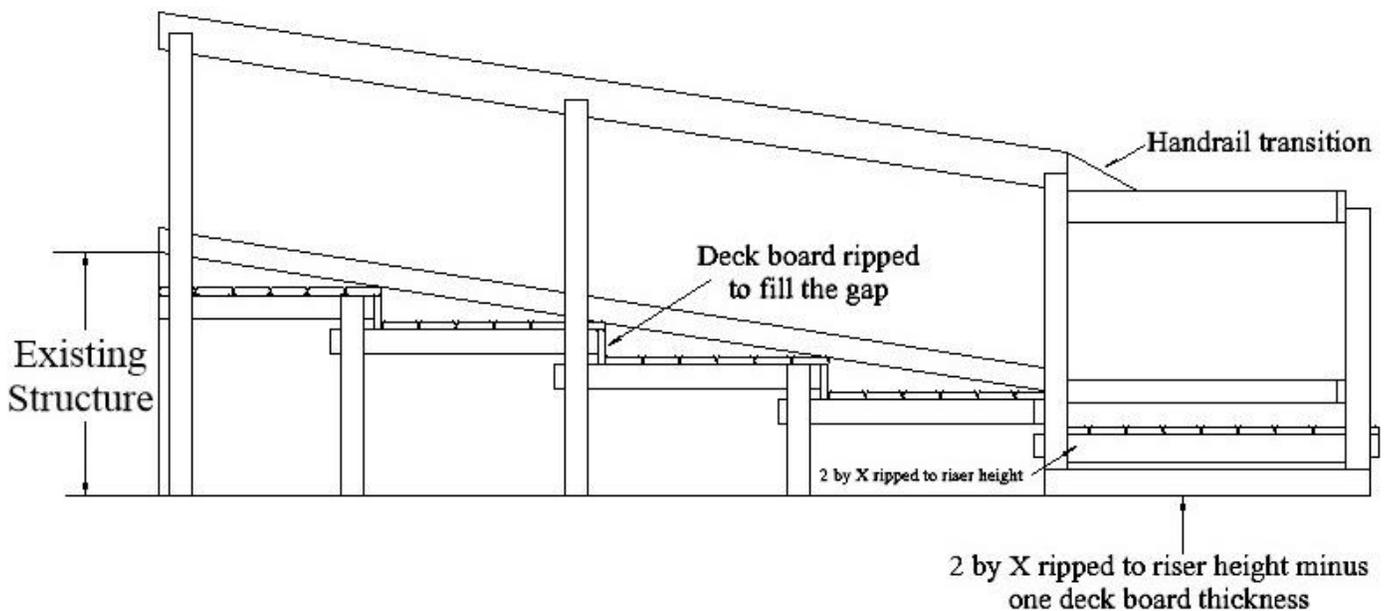

Figure G4

Note: If a toe kick board is used above this assembly make the stringers 30 3/4 in.

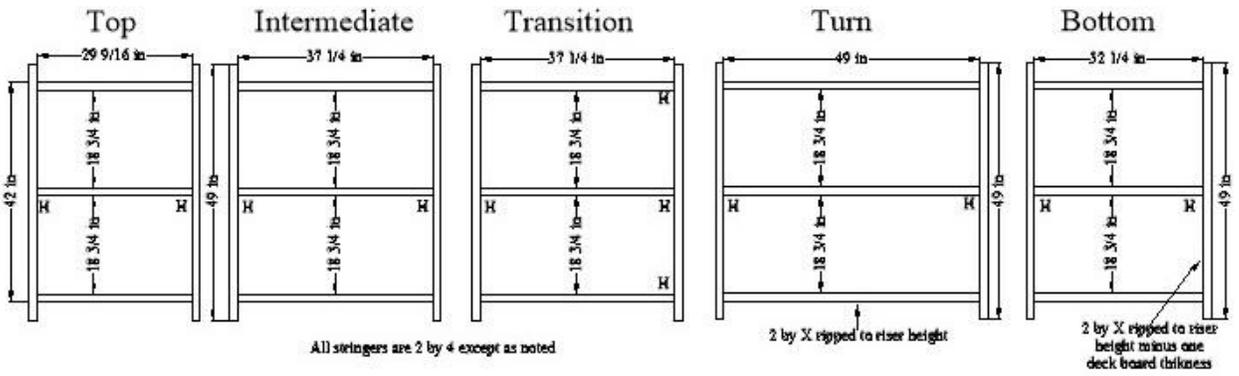

Figure G5

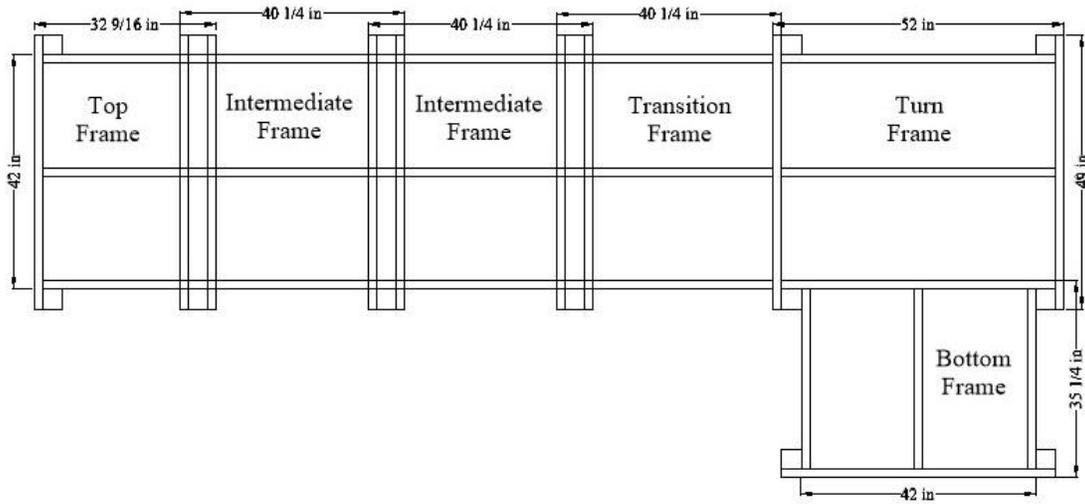

Figure G6

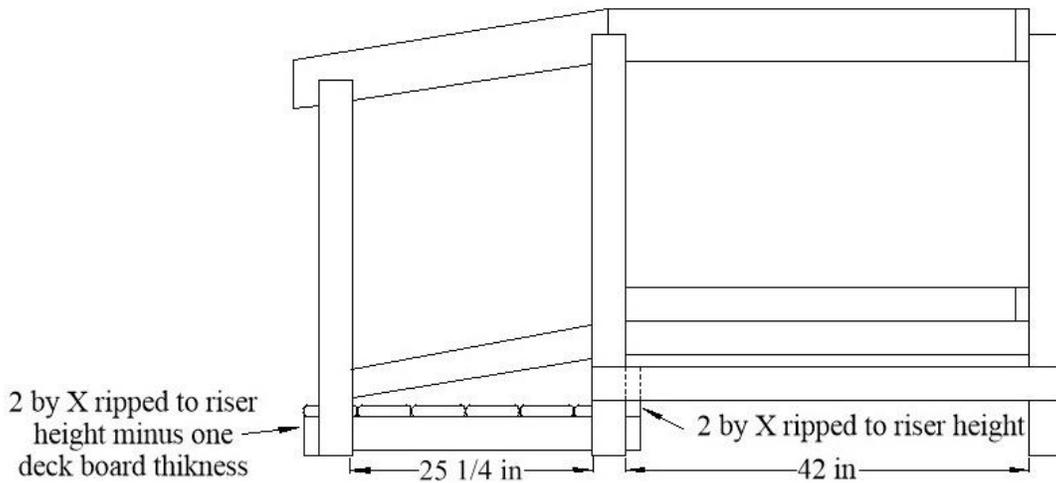

Figure G7

Appendix H. Baluster Guidelines

Baluster notes:

1. Miter a 45° taper on top
2. Cut balusters to 29 7/8" (& ten 33 3/8" End Ramp balusters)
3. Drill holes are 1/8" in diameter
4. Top hole is 2" down (1/2" below taper cut)
5. Bottom hole is 1-1.5" up
6. Put a 2.5" screw in each hole
7. Mount balusters 2.0" down from top of handrail. (Draw a line, & mount to line)
8. Space balusters 3.5" apart
9. Every 4-6 balusters, plumb with a level.

